

CHLORTAINER[®]

TOTAL CONTAINMENT SYSTEM

24 Inch Containment Vessel for Dual (2) 150lb. Cylinders

Valve Identification and
Location Guide & System Layout

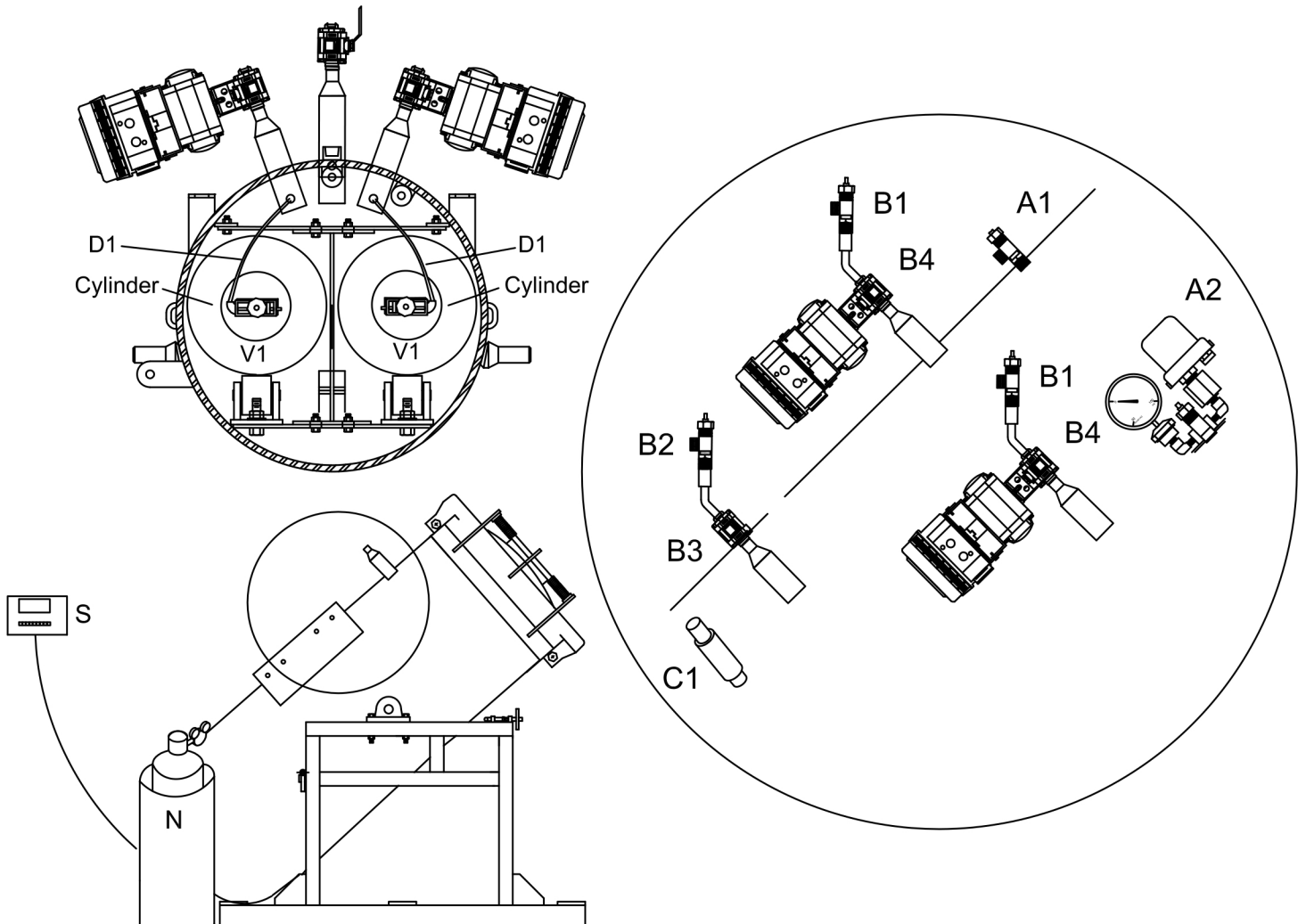

- A1 Pressure Check Valve
- A2 Vacuum/ Pressure Gauge Valve
with optional Pressure Switch
- B1 Exterior Cl₂ Supply Valve
- B2 Alternate Exterior Cl₂ Supply Valve
- B3 Alternate Exterior Cl₂ Ball Valve
- B4 Exterior Cl₂ Ball Valve with
Failsafe Actuator

- C1 Automatic Pressure Relief Valve
- D1 Interior Supply Line
- N Nitrogen Supply with Regulator
- S Wizard 4000 Indicator
- V1 Interior Cylinder Supply Valve

Not Drawn To Scale