

# TGO TECHNOLOGIES, INC.

## 24 Inch Containment Vessel for Dual (2) 150# Cylinders

### Valve Identification and Location Guide & System Layout

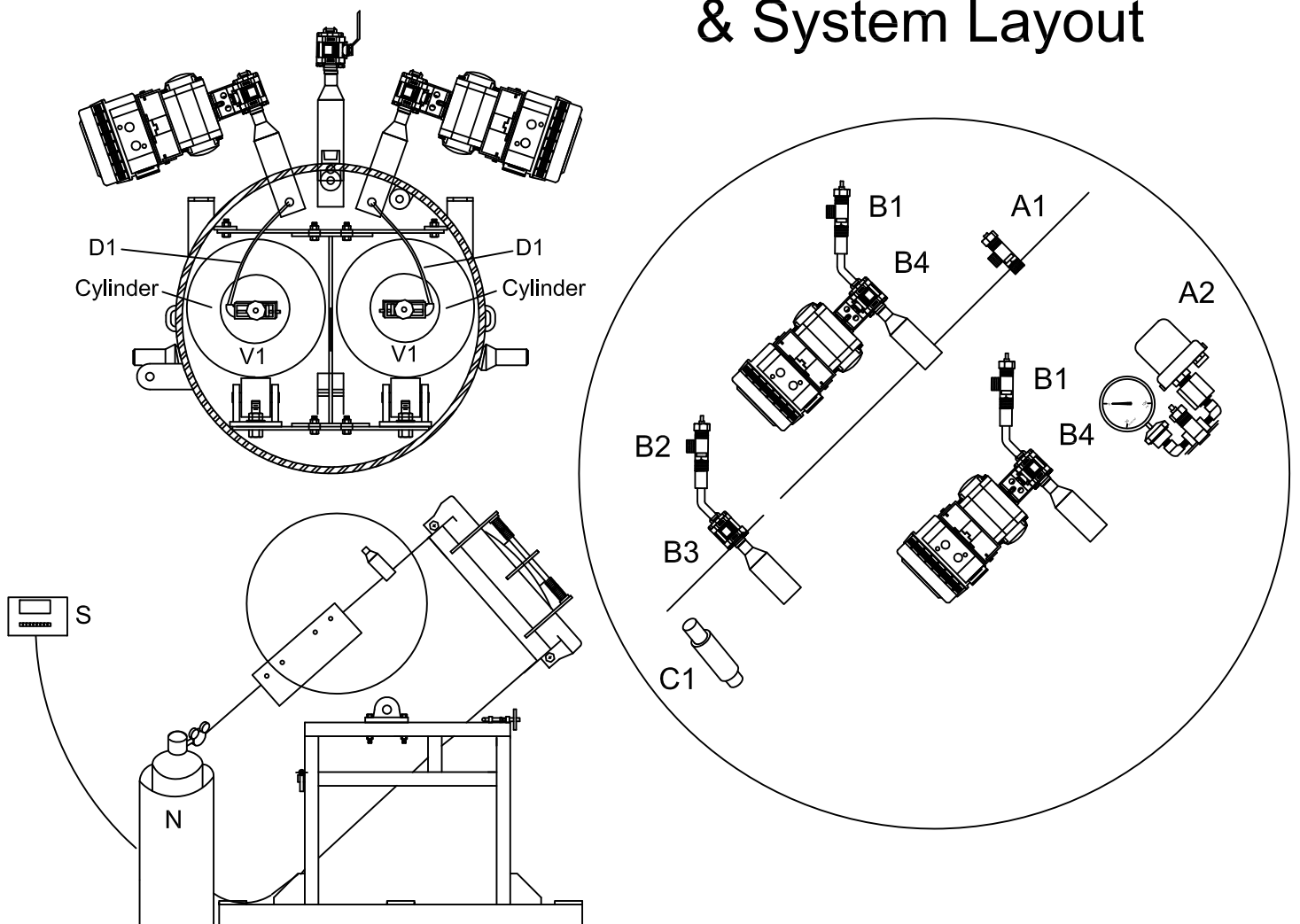

- A1 Pressure Check Valve
- A2 Vacuum/ Pressure Gauge Valve  
with optional Pressure Switch
- B1 Exterior Cl<sub>2</sub> Supply Valve
- B2 Alternate Exterior Cl<sub>2</sub> Supply Valve
- B3 Alternate Exterior Cl<sub>2</sub> Ball Valve
- B4 Exterior Cl<sub>2</sub> Ball Valve with  
Failsafe Actuator

- C1 Automatic Pressure Relief Valve
- D1 Interior Supply Line
- N Nitrogen Supply with Regulator
- S Wizard 4000 Indicator
- V1 Interior Cylinder Supply Valve

Not Drawn To Scale